

# 3L Series

## PRODUCT DATA SHEET

### Metal Bottom Heater

#### Durable, efficient chemical heater

For use in most aqueous alkaline solutions

Low watt density design saves space & ensures long life

Vapor resistant, flame retardant polypropylene terminal enclosure

Grounded construction and built in thermal protector

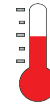

Up to 180°C (82°F)



3,000 watts to 36,000 watts.



200 to 600 Volts  
600V on 4,500W or lower only



Steel, 304 stainless steel, 316 stainless steel and titanium.



cULus (except steel and 600 volts)

3L SERIES, TRIPLE METAL L-SHAPED HEATERS								
WATTS	VOLTS	STD.		STEEL	304 SS	316 SS	TITANIUM	SHIP WGT. Lbs./kg)
		HORIZ. In./(mm)	VERT.* In./(mm)					
3000	240	13	15	3LP3213Q-R**	3LF3213Q-R**	3LS3213Q-R**	3LT3213Q-R**	30
	480	(330)	(381)	3LP3413Q-R**	3LF3413Q-R**	3LS3413Q-R**	3LT3413Q-R**	(13.6)
6000	240	17	37	3LP6217Q-R**	3LF6217Q-R**	3LS6217Q-R**	3LT6217Q-R**	33
	480	(432)	(940)	3LP6417Q-R**	3LF6417Q-R**	3LS6417Q-R**	3LT6417Q-R**	(15)
9000	240	22	37	3LP9222Q-R**	3LF9222Q-R**	3LS9222Q-R**	3LT9222Q-R**	36
	480	(559)	(940)	3LP9422Q-R**	3LF9422Q-R**	3LS9422Q-R**	3LT9422Q-R**	(16.3)
12000	240	26	37	3LP12226Q-R**	3LF12226Q-R**	3LS12226Q-R**	3LT12226Q-R**	39
	480	(660)	(940)	3LP12426Q-R**	3LF12426Q-R**	3LS12426Q-R**	3LT12426Q-R**	(17.7)
15000	240	31	37	3LP15231Q-R**	3LF15231Q-R**	3LS15231Q-R**	3LT15231Q-R**	42
	480	(787)	(940)	3LP15431Q-R**	3LF15431Q-R**	3LS15431Q-R**	3LT15431Q-R**	(19.1)
18000	240	36	50	3LP18236Q-R**	3LF18236Q-R**	3LS18236Q-R**	3LT18236Q-R**	45
	480	(914)	(1270)	3LP18436Q-R**	3LF18436Q-R**	3LS18436Q-R**	3LT18436Q-R**	(20.4)
24000	240	44	50	3LP24244Q-R**	3LF24244Q-R**	3LS24244Q-R**	3LT24244Q-R**	54
	480	(1118)	(1270)	3LP24444Q-R**	3LF24444Q-R**	3LS24444Q-R**	3LT24444Q-R**	(24.5)
27000	480	50	50	3LP27450Q-R**	3LF27450Q-R**	3LS27450Q-R**	3LT27450Q-R**	60
		(1270)	(1270)					(27.2)
30000	480	55	50	3LP30455Q-R**	3LF30455Q-R**	3LS30455Q-R**	3LT30455Q-R**	66
		(1397)	(1270)					(29.9)
36000	480	64	50	3LP36464Q-R**	3LF36464Q-R**	3LS36464Q-R**	3LT36464Q-R**	75
		(1626)	(1270)					(34)

Three phase standard



## Features & Values

- For use in most aqueous alkaline solutions, plating and phosphate tanks. Check solution recommendation chart with your chemical supplier for proper sheath material selection
- Heavy wall metal sheaths available in: steel, 304 stainless steel, 316 stainless steel, titanium
- Watt densities up to 35 watts per square inch (5.4 w/cm<sup>2</sup>) ensure long service life
- Vapor-resistant, flame retardant polypropylene terminal enclosure with 3 ft (.9m) flexible PVC liquid tight conduit.
- Temperature and level controls sized to match the heater
- Lower watt densities for highly viscous solutions

## Specifications

<b>Wattages</b>	3,000 to 36,000 Watts
<b>Voltages</b>	200 to 600 Volts (600V on 4,500W or lower only)
<b>Temperature Range</b>	Up to 180°C (82°F)
<b>Options</b>	<ul style="list-style-type: none"> <li>▫ Special configurations &amp; lengths</li> <li>▫ Longer wire and conduit lengths</li> <li>▫ All metal welded junction box</li> </ul>
<b>Safety Features</b>	<ul style="list-style-type: none"> <li>▫ Grounded construction</li> <li>▫ Thermal protector built in. Replaceable PI protector standard for solutions up to 180°F (82°C).</li> <li>▫ See chart below for protector options</li> </ul>
<b>Certifications</b>	cULus compliant (except 600V)

## Dimensions

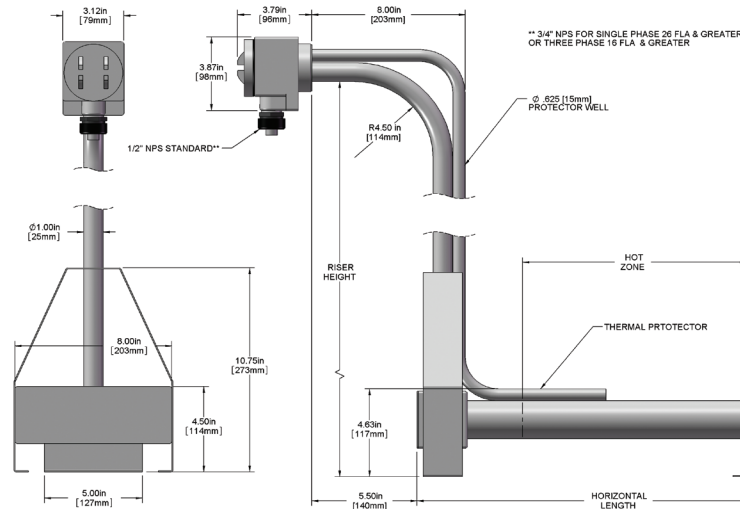

## Model Number Breakdown

Series	Wattage	Voltage	Horizontal Length (In.)	Mounting Flange	Vertical Length (In.)	Riser Option	Phase	Type of Protector	Wire & Conduit Length
3LP = Steel	3 = 3000	1 = 120	13 = 3kW	Q = w/o flange	-R15 = 3kW	Blank = 90° horizontal bend (std)	blank = three phase (std)	<b>Replaceable Fuse</b>	36" length standard (no designator)
3LF = 304 stainless steel	6 = 6000	2 = 240	17 = 6kW	Blank = w/ flange	-R37 = 6kW	-S = straight riser	-1 = single phase	P1 (std) = solutions up to 180°F	Specify variations from standard Ex: -X84 = 84"
3LS = 316 stainless steel	9 = 9000	3 = 380	22 = 9kW		-R37 = 9kW			P4 = solutions up to 230°F	
3LT = Titanium	12 = 12000	4 = 480	26 = 12kW		-R37 = 12kW			P5 = solutions up to 300°F	
	15 = 15000	5 = 415	31 = 15kW		-R37 = 15kW			<b>Resettable Fuse</b>	
	18 = 18000	6 = 600	36 = 18kW		-R50 = 18kW			P2 = solutions up to 180°F	
	24 = 24000	7 = 400	44 = 24kW		-R50 = 24kW			P6 = solutions up to 230°F	
	27 = 27000	8 = 208	50 = 27kW		-R50 = 27kW			P7 = solutions up to 300°F	
	30 = 30000	9 = 220	55 = 30kW		-R50 = 30kW				
	36 = 36000	0 = 200	64 = 36kW		-R50 = 36kW				

